

A B A N A K I

OIL GRABBER® MODEL 4

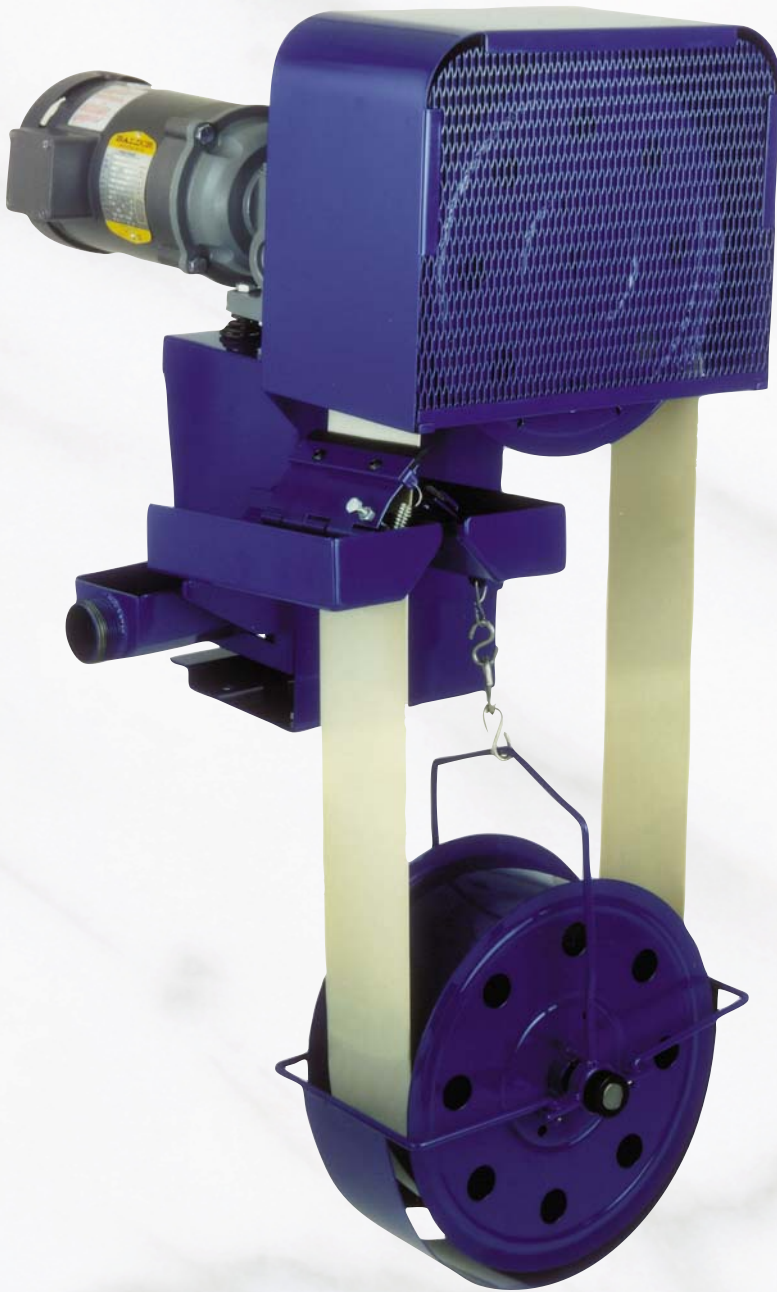

Model 4 shown with optional tail pulley cage and tether assembly.

Enjoy the Benefits of Oil Skimming!

- Most inexpensive way to remove oil from water
- Saves coolants by removing tramp oil
- Conserves parts wash water by removing oily wastes
- Prevents plugging of spray heads and filters
- Reduces fluid disposal costs
- Skimmed oil can be recycled and reused as a lubricant or fuel
- Helps meet government requirements for water discharge

General Description

The Abanaki Model 4 Oil Grabber is a dependable and effective means of removing oil from water and water-base solutions. Often, skimming by itself will reduce oil to an acceptable level of water purity. Depending on the characteristics of the liquid, it is possible for the Model 4 alone to reduce oil content to less than five parts per million in water. The unit can be used as a pretreatment before filtration, and in conjunction with coalescing systems.

The Model 4 utilizes a continuous belt and wiper to remove up to 20 gallons of oil per hour from the fluid surface. The belt, operating on a motor and pulley system, runs through contaminated liquid to pick up oil from the surface. After traveling over the head pulley, the belt passes through tandem wiper blades where oil is scraped off both sides of the belt and discharged. The tail pulley has flanges which allow it to roll freely on the inside of the belt without becoming dislodged. It requires no bearings and does not need to be fastened to the tank. If turbulent conditions exist, the optional tether and cage assembly prevents the tail pulley from being dislodged.

Oil skimming makes use of the differences in specific gravity and surface tension between oil and water. These physical characteristics allow the belt to attract oil and other hydrocarbon liquids from the surface of the fluid. The Model 4 can be used in tanks with depths as shallow as one foot, or as deep as 100 feet.

The Model 4 Advantages

- A single unit elevates and separates oil
- Lifts oil any distance without the need of expensive pumps
- Maintains skimming efficiency with fluctuating fluid levels
- Can be used in depths as shallow as one foot, or as deep as 100 feet
- Requires no tank modifications in most applications
- Operates in turbulent liquid using optional tail pulley cage and tether assembly
- Easy mounting and fast cleaning, with minimal maintenance

Where To Use The Model 4

The Model 4 is designed for those applications where other models provide excess capacity, or physically will not fit. From a mere shimmer on top of water to a heavy oil slick, the Model 4 performs efficiently, removing up to 20 gallons of oil per hour.

Typical Applications

- Wastewater sumps
- Food processing plants
- Ships' bilges
- Parts washers
- Parking lots, garages, and service facilities
- Aircraft service areas and tarmac runoff
- Coolant systems
- Outdoor ponds, lakes, and basins
- Truck, locomotive, and other mobile equipment washing facilities
- Heat treating fluids
- Underground tanks

Rugged Construction for Harsh Conditions

The Model 4 is designed to last for many years. With the proper configuration it can handle liquid temperatures up to 212 °F, and the pH of the fluid can range from 1 to 13. Belts are made of corrosion-resistant steel, carbon steel, elastomer, and a specially engineered polymer.

The skimmer drive includes an oil filled gear reducer with bronze gears and ball bearings. The motor, reducer, and powder coated finish of the weldments give the Model 4 exceptionally long life, even under the harshest conditions.

Key Features of the Model 4:

- Requires only a small area in the tank or sump
- Easy mounting
- High temperature capability
- Chip resistant powder finish
- Hazardous duty and food grade options
- Custom designs and turnkey systems available
- Fast cleaning with minimal maintenance

MODEL 4 WITH FLAT MOUNT IN USE

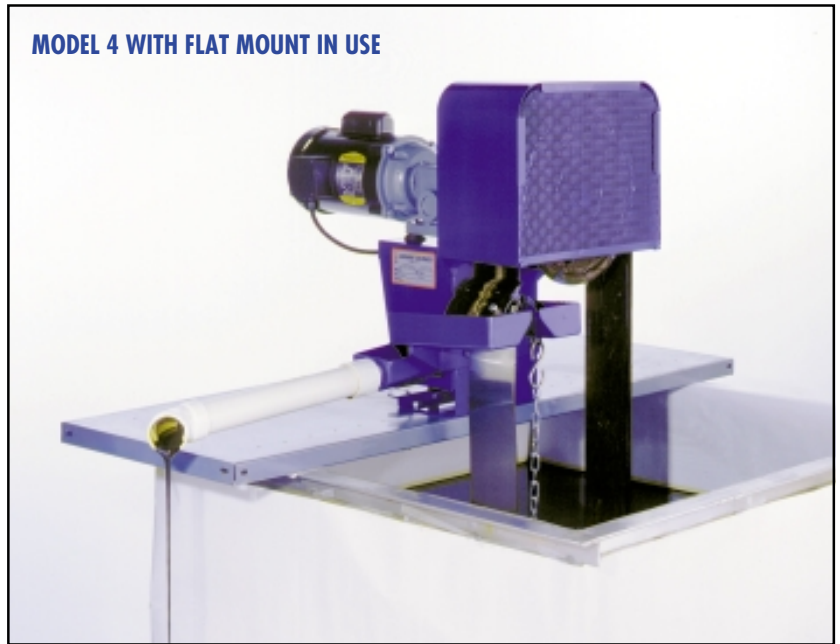

TAIL PULLEY OPTIONS

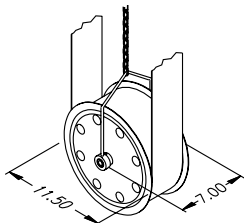

Tail Pulley with Yoke and Chain Option

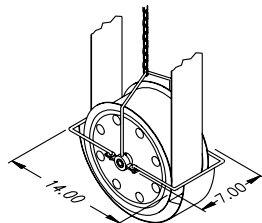

Tail Pulley with Yoke, Chain and Retainer Option

WIPER ASSEMBLY DETAIL

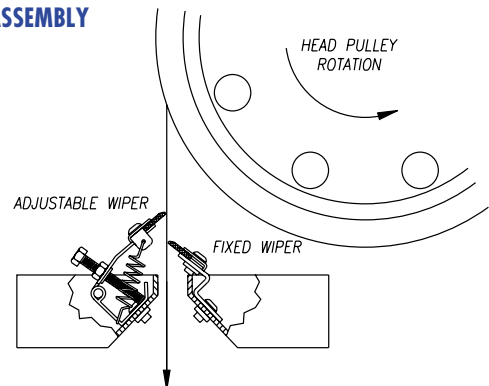

Specifications:

Oil Removal Rate	16 gph (60 lph) with standard tail pulley 20 gph (75 lph) with high capacity tail pulley (Removal rate is based on 30 weight oil in water.)
Tail Pulley	Specify standard or high capacity. (The high capacity option uses a patented pulley design that improves the adherence of oil to the inside of the belt, thus increasing the removal rate.)
Motor	Fractional HP, TEFC, motor operating on either 115/230VAC, single phase, 60Hz or 230/460 VAC, three phase, 60Hz. Optional: 50Hz power source; explosion proof; drip proof; pneumatic; and wash down duty motors.
Belt Width	4 in. (10 cm)
Belt Length	User specified (see "Belt Selection" next page.)
Belt Material	Specify corrosion-resistant steel, carbon steel, elastomer, or a specially engineered poly. (See "Belt Selection.")
Wiper	Nitrile (Standard); CRV (Optional) or Ceramic hybrid (Optional). Specify wiper material based on temperature and fluid compatibility. (See "Operating Limits.")
Mounting Method	Standard: Bracket for customer-supplied steel channel, with oil discharge through the channel, or flat surface mount with oil discharge through a 1-1/2 in. (3.75 cm) NPT male pipe fitting.
Weights ¹	Drive assembly and housing with motor, without belt or tail pulley: 71 lbs. (32 kg) max. Standard or high capacity tail pulley: 8 lbs. (3.6 kg) 4 ft. corrosion-resistant steel belt: 4 lbs. (1.8 kg) (belt weight varies according to actual length specified)
Options (Specify)	<ul style="list-style-type: none"> • Tail pulley cage and tether assembly for operation in turbulent liquids . • 1-1/2" PVC discharge pipe kit • Floor mounted support stand. • 316 stainless steel housing. • Oil Concentrator[®] for virtually water-free oil (See Abanaki Oil Concentrator[®] on next page.) • Float switch with signal light (fits in 3/4" drum bung) to prevent discharge drum overflow. • Trough heaters • Poly-shelters, reinforced for durable protection in outside applications • Timer and electrical controls

Operating Limits

Wipers²

Temperature of Liquid	pH 1-5 (acidic)	pH 6-8 (neutral)	pH 9-14 (alkaline)
33°F-180°F (0.5°C-82°C)	Ceramic hybrid, CRV	Ceramic hybrid, CRV, nitrile	Ceramic hybrid, CRV, nitrile
181°F-212°F (83°C-100°C)	CRV	CRV	CRV

Belts²

Temperature of Liquid	pH 1-5 (acidic)	pH 6-8 (neutral)	pH 9-14 (alkaline)
33°F-140°F (0.5°C-60°C)	Elastomer	Poly, Elastomer	Poly, Elastomer
33°F-180°F (0.5°C-82°C)	Corrosion Resistant	Corrosion Resistant, Carbon Steel, Poly	Corrosion Resistant, Poly
181°F-212°F (83°C-100°C)	CR steel	Corrosion Resistant, Carbon Steel	Corrosion Resistant

Standard Configuration

The standard Model 4 is supplied with a motor belt guard, spring-loaded adjustable wiper blade assembly, skimmer belt, tail pulley, and assembly instructions.

Specification Notes:

1. The Model 4 is UPS shippable.
2. Consult factory for recommendations covering operating conditions not listed here.

MODEL 4 MOUNTING

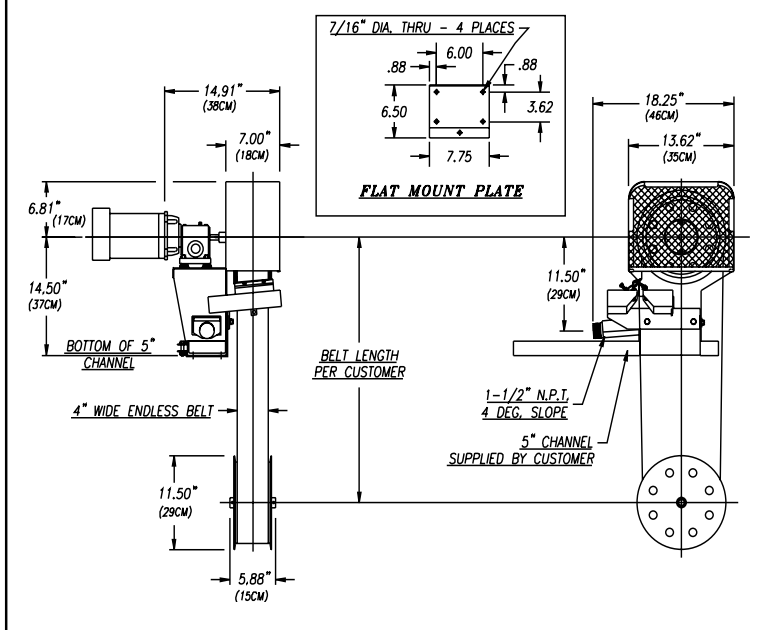

Belt Selection

Belt Length

To specify the belt length: Measure from the drive unit mounting plane to the surface of the liquid at its lowest level and add 24 inches (61 cm). (Generally, the lowest level allowed is about one foot, and can never be the bottom of the tank. The tail pulley should be submerged below the liquid surface.)

Belt Material

Experience has shown that belt skimmers require a minimum square footage of space for installation and operation, yet they surpass the requirements for most applications. Abanaki single material belts include corrosion-resistant steel (standard), carbon steel, elastomer, or a specially engineered poly. There is no delamination to worry about with a single material belt.

Corrosion-resistant Steel - Proven to be a reliable belting material of choice: durable and trouble free. This material stands up to high temperatures and harsh chemicals.

Carbon Steel - Used in applications where the skimmer is operating 24 hours a day or when the liquid has neutral pH.

Elastomer - Used in applications where abrasive particles are present or when physical abuse of the belt is likely.

Engineered Poly - Used in relatively high heat without stretching. Strong chemical resistance. Capable of picking up many emulsions.

When in doubt, consult factory for advice on the best belt for your application.

Wiper Selection

Nitrile: Standard, used in most applications not involving strong chemicals or high heat.

CRV: Used in applications with strong chemicals or high heat.

Ceramic Hybrid: Used in applications with low lubricity. Acid & chemical resistant.

ABANAKI'S Oil Concentrators®

The Oil Concentrator® is an option available on all ABANAKI oil skimmers. Under most operating conditions ABANAKI oil skimmers will pick up oil with less than 5% water. But as surface oil is reduced to a thin layer (1/16 to 1/8 inches thick), more water or coolant may also be picked up along with the oil. When used in tandem with the oil skimmer, an Oil Concentrator will solve this problem, and provides virtually complete oil /water separation, saving money and improving the efficiency of the skimmer.

Based on the principle of gravity separation, the Oil Concentrator uses no electricity, timers, sensors, pumps, or other moving parts. The Oil Concentrator sits behind the skimmer and receives its discharged oil. The unit comes complete with a mounting bracket, removable sludge screen and a drain plug to ease clean up. For higher viscosity oils or low temperature applications, a thermostatically controlled heater is available as an option.

Abanaki has thousands of skimmers installed worldwide at leading companies such as...

American Cyanamid
Armstrong World Industries
Bethlehem Steel
Boeing
British Steel
Bureau of Reclamation
Caterpillar

Chevron
Corning
Dow Chemical
Eaton
Flying J
Ford Motor
General Electric

Henry Filters
John Deere
Kaiser Aluminum
Mazak
Monroe Auto Equipment
New York Power Authority
Nissan Motor
Nucor-Yamato Steel

Outboard Marine
TRW
United Airlines
USS Great Lakes Fleet
Volvo AB
Wartsila Diesel
Westinghouse Electric

Abanaki Oil Skimmer Quick Selector Chart

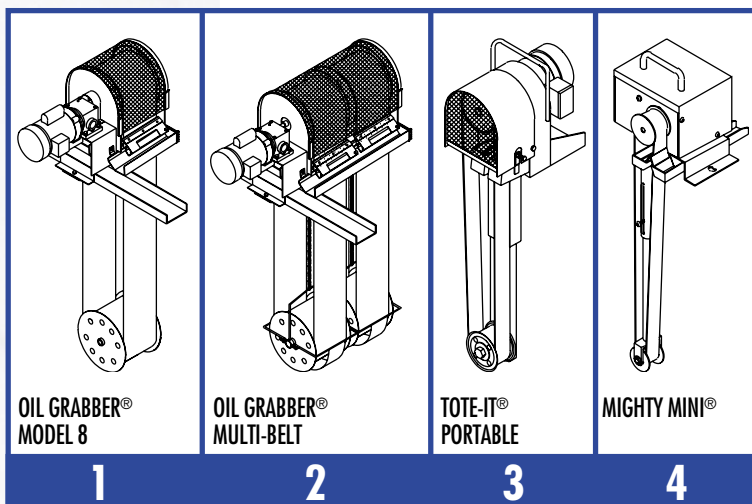

Other Oil Skimming Products From Abanaki:

- For Most Applications:**
Single 8-inch wide belt (20.3 cm)
Any length belt
Capacity: 40 GPH (151.4 LPH)
- For High Volume:**
Two to five 8-inch belts (20.3 cm)
Any length belts
Capacity: to 200 GPH (757.1 LPH)
- Portable for Moderate Capacity Applications:**
Single belt: 2-inch or 4-inch (5.1 or 10.2 cm)
Belt length: 1'-6" to 5'-0" (45.2 to 152.4 cm)
Capacity: 6 GPH - 2" belt (15.1 LPH - 5.1 cm belt)
12 GPH - 4" belt (22.7 LPH - 10.2 cm belt)
- Small Applications (Parts Washers, CNC Machines, 55 Gal. Drums):**
Single belt: 1-inch or 2-inch (25.4 or 50.8 mm)
Belt length: 6", 12", 18", 24" (153, 305, 458, 610 mm)
Capacity: 1 GPH - 1" belt (3.81 LPH)
2 GPH - 2" belt (5.71 LPH)

OIL GRABBER® MODEL 4

For more information, please contact:



**WMI Wolfgang Moik
Industrieprodukte**

Urstein Nord 51, 5412 Puch bei Hallein, Austria

Telefon +43 6246 73 412

Telefax +43 6246 73 412-22

office@wmi.co.at

www.wmi.co.at

Optional Equipment Shown In Some Views. © Abanaki Corporation, 1998