

A B A N A K I

OIL GRABBER® MODEL 8²



Model 8² shown with optional tail pulley and tether assembly

Enjoy the Benefits of Oil Skimming!

- Most inexpensive way to remove oil from water
- Saves coolants by removing tramp oil
- Conserves parts wash water by removing oily wastes
- Prevents plugging of spray heads and filters
- Reduces fluid disposal costs
- Skimmed oil can be recycled and reused as a lubricant or fuel
- Helps meet government requirements for water discharge

General Description

The Abanaki Model 8² is a dependable and effective means of removing free floating oil from water and water-base solutions. In some cases, skimming by itself will reduce oil to an acceptable level of water purity. The unit can be used as a pretreatment before filtration, and in conjunction with coalescing systems.

The Model 8² utilizes a continuous belt and wiper to remove up to 40 gallons of oil per hour from the fluid surface. The belt, operating on a motor and pulley system, runs through contaminated liquid to pick up oil from the surface. After traveling over the head pulley, the belt passes through tandem wiper blades where oil is scraped off both sides of the belt and discharged. The tail pulley has flanges which allow it to roll freely on the inside of the belt without becoming dislodged. It requires no bearings and does not need to be fastened to the tank. If turbulent conditions exist, an optional tether and cage assembly prevents the tail pulley from being dislodged.

Oil skimming makes use of the differences in specific gravity between oil and water. These physical characteristics allow the belt to attract oil and other hydrocarbon liquids from the surface of the fluid. The Model 8² can be used in tanks with depths as shallow as one foot, or as deep as 100 feet.

The Model 8² Advantages

- A single unit elevates and separates oil
- Lifts oil any distance without the need of expensive pumps
- Maintains skimming efficiency with fluctuating fluid level
- Can be used in depths as shallow as one foot, or as deep as 100 feet
- Requires no tank modifications in most applications
- Operates in turbulent liquid using optional tail pulley cage and tether assembly
- Easy mounting and fast cleaning, with minimal maintenance

OIL GRABBER[®] MODEL 8²

Where To Use The Model 8²

The Model 8² is the most widely used Abanaki skimmer. Its size and removal capacity make it suitable for most applications. From a mere shimmer on top of water to a heavy oil slick, the Model 8² performs efficiently, removing up to 40 gallons of oil per hour.

Typical Applications

- Wastewater sumps
- Heat treating fluids
- Parts washers
- Food processing plants
- Coolant systems
- Parking lots, garages, and service facilities
- Outdoor ponds, lakes, and basins
- Underground tanks
- Ships' bilges
- Aircraft service areas and tarmac runoff
- Truck, locomotive, and other mobile equipment washing facilities

Rugged Construction for Harsh Conditions

The Model 8² is designed to last for many years. With the proper configuration it can handle liquid temperatures up to 212 °F, and the pH of the fluid can range from 1 to 13. Belts are made of corrosion-resistant steel, carbon steel, elastomer, and a specially engineered polymer.

The skimmer drive includes an oil filled gear reducer with bronze gears and ball bearings. The motor, reducer, and powder coated finish of the weldments give the Model 8² exceptionally long life, even under the harshest conditions.

Key Features of the Model 8²:

- Requires only a small area in the tank or sump
- Easy mounting
- High temperature capability
- Chip resistant powder finish
- Hazardous duty and food grade options
- Custom designs and turnkey systems available
- Fast cleaning with minimal maintenance

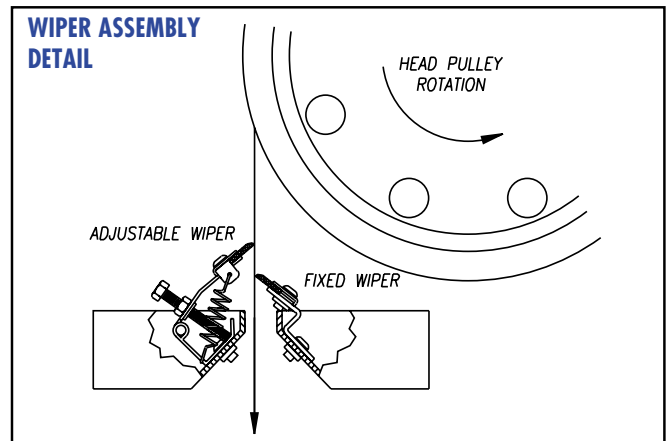
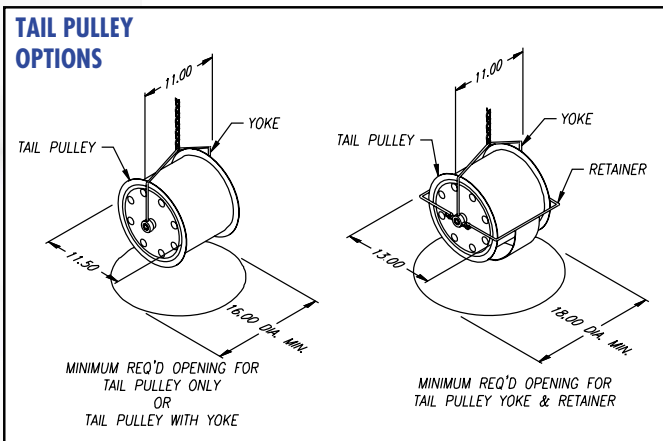
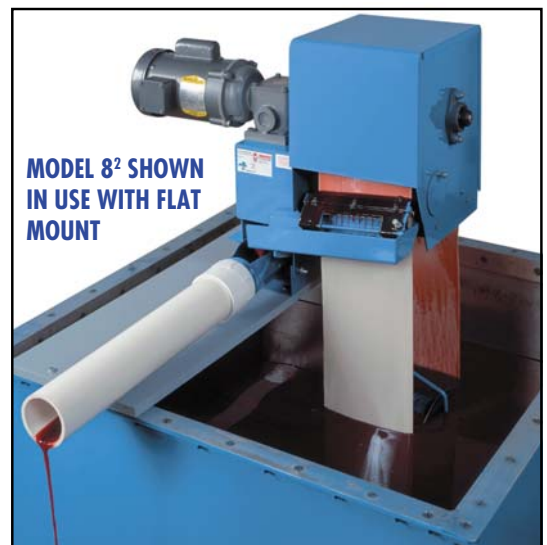

MODEL 8² CHANNEL MOUNT

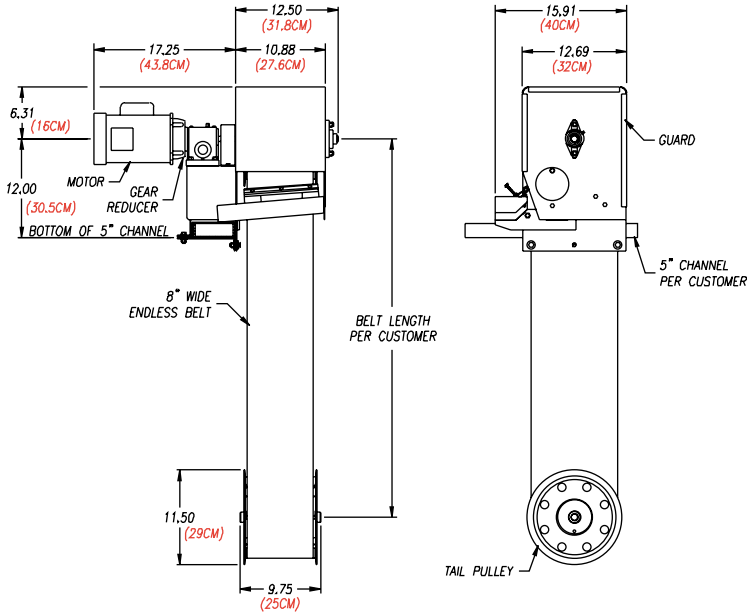

MODEL 8² FLAT MOUNT

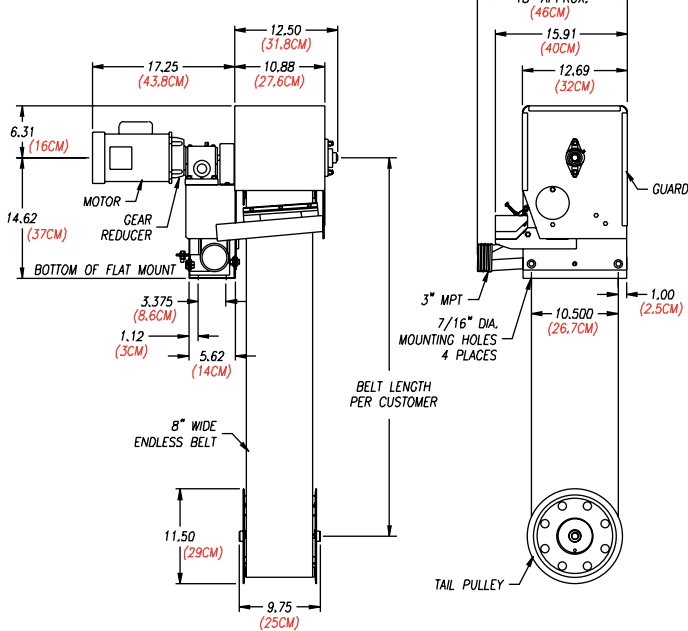

Specification Notes:

1. The Model 8² is UPS shippable.
2. Consult factory for recommendations covering operating conditions not listed here.

Specifications:

- Oil Removal Rate** 32 gph (120 lph) with standard tail pulley.
40 gph (150 lph) with high capacity tail pulley.
(Removal rate is based on 30 weight oil in water at ambient temperature.)
- Tail Pulley** Specify standard or high capacity.
(The high capacity option uses a patented pulley design that improves the adherence of oil to the inside of the belt, thus increasing the removal rate.)
- Motor** Fractional hp, TEFC, gear motor operating on either 115/230VAC, single phase, 60Hz or 230/460 VAC, three phase, 60Hz.
Optional: 50Hz power source; explosion proof; drip proof; pneumatic; and wash down duty motors.
- Belt Width** 8 in. (20 cm).
- Belt Length** User specified. (See Belt Selection page.)
- Belt Material** Specify corrosion-resistant steel, carbon steel, or specially engineered poly. (See Belt Selection page.)
- Wiper** Nitrile (Standard); CRV (Optional) or Ceramic hybrid (Optional). Specify wiper material based on temperature and fluid compatibility. (See "Operating Limits.")
- Mounting Method** Standard: Bracket for customer-supplied steel channel, with oil discharge through the channel.
Option: Flat surface mount with oil discharge through a 3 in (7.5 cm) NPT male pipe fitting.
- Weights¹** Drive assembly and housing with motor, without belt or tail pulley: 82 lbs. (37 kg) max.
Standard tail pulley: 10 lbs. (4.5 kg).
Optional high capacity tail pulley: 8 lbs. (3.6 kg)
4 ft. corrosion-resistant steel belt: 7 lbs. (3.2 kg)
(belt weight varies according to actual length specified)
- Options (Specify)**
- Flat surface mount kit
 - Tail pulley cage and tether assembly for operation in turbulent liquids.
 - 3" PVC discharge pipe kit
 - Floor mounted support stand.
 - 316 stainless steel housing.
 - Thermostatically controlled heaters (115/230VAC, 900 Watts; the heater hood replaces the standard drive unit cover.)
 - Oil Concentrator[®] for virtually water-free oil (see Abanaki Oil Concentrator[®] on next page.)
 - Float switch with signal light (fits in 3/4" drum bung) to prevent discharge drum overflow.
 - Poly-shelters, reinforced for durable protection in outside applications
 - Timer and electrical controls

Operating Limits

Wipers²

Temperature of Liquid	pH 1-5 (acidic)	pH 6-8 (neutral)	pH 9-14 (alkaline)
33°F-180°F (0.5°C-82°C)	Ceramic hybrid, CRV	Ceramic hybrid, CRV, nitrile	Ceramic hybrid, CRV, nitrile
181°F-212°F (83°C-100°C)	CRV	CRV	CRV

Belts²

Temperature of Liquid	pH 1-5 (acidic)	pH 6-8 (neutral)	pH 9-14 (alkaline)
33°F-140°F (0.5°C-60°C)	Elastomer	Poly, Elastomer	Poly, Elastomer
33°F-180°F (0.5°C-82°C)	Corrosion Resistant	Corrosion Resistant, Carbon Steel, Poly	Corrosion Resistant, Poly
181°F-212°F (83°C-100°C)	CR steel	Corrosion Resistant, Carbon Steel	Corrosion Resistant

Standard Configuration

The standard Model 8² is supplied with a motor belt guard, spring-loaded adjustable wiper blade assembly, skimmer belt, tail pulley, and assembly instructions.

ABANAKI'S Oil Concentrators®

The Oil Concentrator® is an option available on all ABANAKI oil skimmers. Under many operating conditions ABANAKI oil skimmers will pick up oil with less than 5% water. But as surface oil is reduced to a thin layer (1/16 to 1/8 inches thick), more water or coolant may also be picked up

along with the oil. When used in tandem with the oil skimmer, an Oil Concentrator will solve this problem, and provides virtually complete oil /water separation, saving money and improving the efficiency of the skimmer.

Based on the principle of gravity separation, the Oil Concentrator uses no electricity, timers, sensors, pumps, or other moving parts. The Oil Concentrator sits behind the skimmer and receives its discharged oil. The unit comes complete with a mounting bracket, removable sludge screen and a drain plug to ease clean up. For higher viscosity oils or low temperature applications, a thermostatically controlled heater is available as an option.

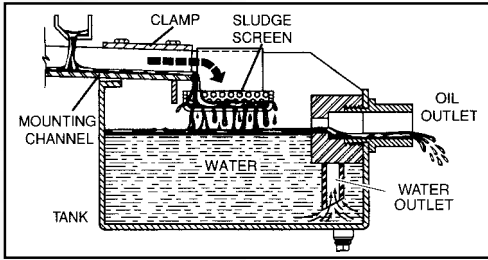

Abanaki has thousands of skimmers installed worldwide at leading companies such as...

Army Corps of Engineers
Bethlehem Steel
Boeing
British Steel
Bureau of Reclamation
Caterpillar
Chevron
Corning
Dow Chemical

Dupont
Eaton
Ford Motor
General Electric
General Motors
Henry Filters
Honda
John Deere
Kaiser Aluminum

Mazak
Monroe Auto Equipment
New York Power Authority
Nissan Motor
Nucor-Yamato Steel
Outboard Marine
Quaker Oats
Timken
Toyota

TRW
Underwriters Lab
United Airlines
U.S. Bureau of Reclamation
USS Great Lakes Fleet
Volvo AB
Wartsila Diesel
Westinghouse Electric

Abanaki Oil Skimmer Quick Selector Chart

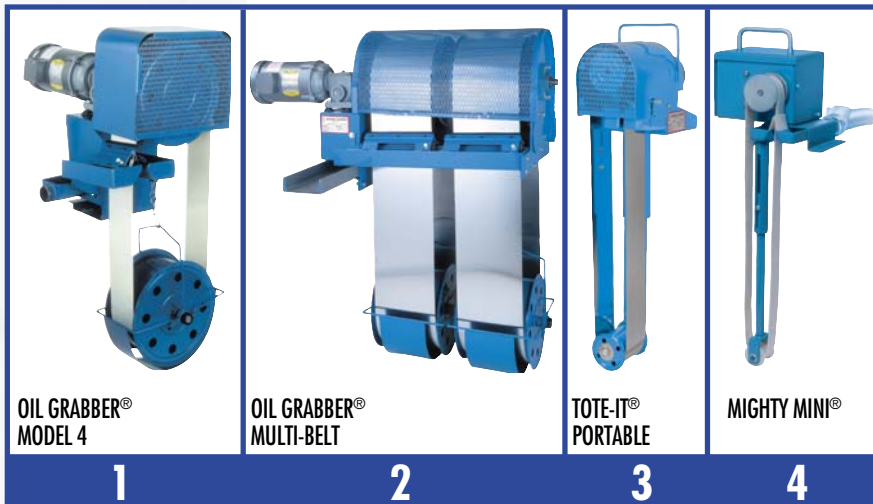

Other Oil Skimming Products From Abanaki:

- OIL GRABBER MODEL 4 For Mid Volume**
Single 4-inch wide belt (10 cm)
Any length belt
Capacity: 20 GPH (75 LPH)
- OIL GRABBER MULTI-BELT For High Volume**
Two to five 8-inch belts (20.3 cm)
Any length belts
Capacity: to 200 GPH (757.1 LPH)
- TOTE-IT PORTABLE For Moderate Capacity Applications**
Single belt: 2-inch or 4-inch (5.1 or 10.2 cm)
Belt length: 1' - 6" to 5'-0" (45.2 to 152.4 cm)
Capacity: 6 GPH - 2" belt (15.1 LPH - 5.1 cm belt)
12 GPH - 4" belt (22.7 LPH - 10.2 cm belt)
- MIGHTY MINI For Small Applications (Parts Washers, CNC Machines, 55 Gal. Drums)**
Single belt: 1-inch or 2-inch (25.4 or 50.8 mm)
Belt length: 6", 12", 18", 24" (153, 305, 458, 610 mm)
Capacity: 1 GPH - 1" belt (3.81 LPH)
2 GPH - 2" belt (5.71 LPH)

OIL GRABBER® MODEL 8²

For more information, please contact:



**WMI Wolfgang Moik
Industrieprodukte**

Urstein Nord 51, 5412 Puch bei Hallein, Austria

Telefon +43 6246 73 412

Telefax +43 6246 73 412-22

office@wmi.co.at

www.wmi.co.at

Optional Equipment Shown In Some Views.