

ABANAKI TUBE SKIMMER

TUBETASTIC!™ OIL SKIMMER

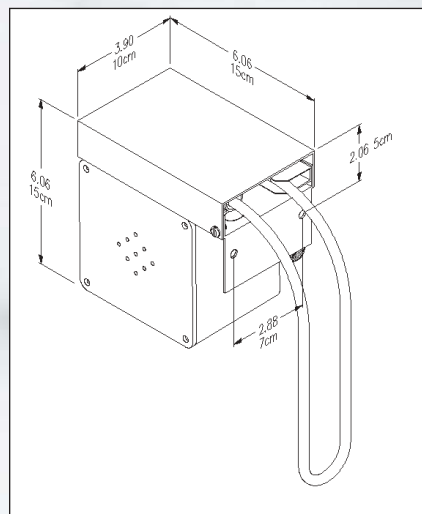

This unit can be easily mounted on the side of virtually any machining center coolant sump. By use of an existing opening or by making a small access cutout, the collector tube runs through the surface of the coolant and collects the unwanted oils. The oil then flows out the discharge tube into any waste oil container for easy disposal.



The Abanaki TubeTastic! oil skimmer can be used on machining centers with little or no access to the coolant sump from above. This unit can skim oil from chip conveyors or even totally enclosed machining centers!

- Fan cooled continuous duty motor
- Oil pickup rate of up to 5,5 l/h (1½ g.p.h.)
- Works in places where other skimmers can't
- Standard tube lengths in reach: 12", 18" and 24". Longer lengths available.

Technical Information:

Dimensions:	4" W x 6" L x 6" D
Weight:	6 lb.
Motor type:	230v, 1ph, 50Hz
Max. Operating Temp:	200° F, 93° C

WMI

**WMI Wolfgang Moik
Industrieprodukte**

Urstein Nord 51, 5412 Puch bei Hallein, Austria

Telefon +43 6246 73 412

Telefax +43 6246 73 412-22

office@wmi.co.at

www.wmi.co.at